

# SERIES 5



DEUTZ-FAHR  
5105 - 5115 - 5125





THE 5 SERIES. THE COMFORT  
CLASS IN THE COMPACT CLASS.



5 SERIES	5105	5115	5125
Maximum output (kW/HP)	80.8/110	87.5/119	92.8/126

For efficient work with compact tractors, working, driving and operating comfort is as important as versatility. Agriculture, feed cultivation, dairy cattle husbandry or municipal uses – the range of applications is getting bigger and bigger while working days are getting longer and longer. Only when a compact tractor is 100% compatible with the task profile of the company is it possible to work with economic success. Only when the comfort is right are the performance and therefore the motivation of the driver maintained over the long run. DEUTZ-FAHR has developed the 5 Series for this purpose. Three models from 110 HP to 126 HP, which are distinguished by their versatility, technology and

maximum comfort. The high-comfort cab is placed on Hydro-Silent blocks. Up to 40% less noise and vibration in the cab are the result. The new spring-loaded front axle provides driving comfort, safety and grip in all ground conditions. The new light package for illuminating your surroundings in poor visibility conditions. Whatever your requirements for a compact tractor, DEUTZ-FAHR will meet them with state-of-the-art technology, countless configuration options and exceptional comfort. At DEUTZ-FAHR, you will find the largest model range of compact tractors.



A green tractor is pulling a yellow trailer under a dark, overhanging roof. The scene is set at dusk, with a sky of blue and pinkish clouds. The tractor's headlights are on, and the trailer has a red and white striped safety marker. The overall mood is professional and focused on agricultural work.

Into the cab. Out on the field.  
The 5 series makes work fun.  
Unique versatility combined with  
high working, driving and operating  
comfort are the foundation for your  
successful work.



**STATE-OF-THE-ART  
WORKING COMFORT.**

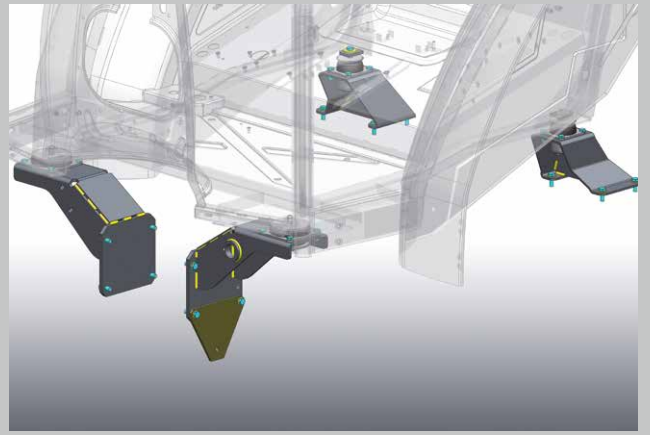

Up to 40% less vibration in the cab thanks to the Hydro-Silent block bearing.



The headlamp package. For illuminating your surroundings in poor visibility conditions. Eight work lights on the roof and on side posts. Two work lights and two LED luminaires in the bonnet.



Best upward visibility. Three different roof variants.

Whoever hops on board the 5 series notices it immediately – top comfort and quietness characterize the cab. The design is comparable to that of a comfort-class car. Clean lines, a bright, friendly atmosphere, short handle paths and a clear view on all sides promote precise and efficient work. Vibrations and noise stay outside. The cab, mounted on Hydro-Silent blocks, absorbs up to 40% more vibrations than ever before. At night or in bad weather, the headlamp package with eight work lights (six in the roof and two on the side posts), as well as two work lights and LED luminaires in the bonnet, guarantee a perfect

illumination of the entire working area. Three roof variants are available. A standard roof with FOPS safety features, a glass roof without FOPS and a polycarbonate open-view roof with FOPS for best possible upwards visibility during front loader operations. Whatever your needs, the modern, highly comfortable cab motivates every driver to maximum performance.



**THE DRIVER AS THE MASTER OF THE FIELD: QUICK AND EASY TO ALL COMMANDS AT THE PRESS OF A BUTTON.**





Working comfort at DEUTZ-FAHR means that the tractor adapts to the driver and not vice versa. Comfortable and intuitive operation when performing any and all work was the goal during the overhaul of the cab. As usual with DEUTZ-FAHR, all controls are colour-coded and logically arranged according to the frequency of use. The illuminated information centre in the steering column continuously provides the driver with all relevant information about the operating status of the tractor. Changing gears simply by pressing a button on the gear lever provides particular ease. The auxiliary control units can be conveniently and precisely operated on the control panel. Two engine speeds can also be saved. For routine tasks, merely the press of a button now suffices for working or driving within the most efficient range.



Gear changing ease simply by pressing a button.



Operation of the auxiliary control units. Comfortable and precise.



The information centre. All operating conditions constantly at a glance. Analogue and digital.



Two engine speeds can be saved. Efficiency preprogrammed for routine work.





The 5 series has many advantages: high comfort, maximum versatility, best technology. But its greatest strength lies in the perfect interplay of all these advantages. That's precisely what makes these compact tractors powerful all-rounders.

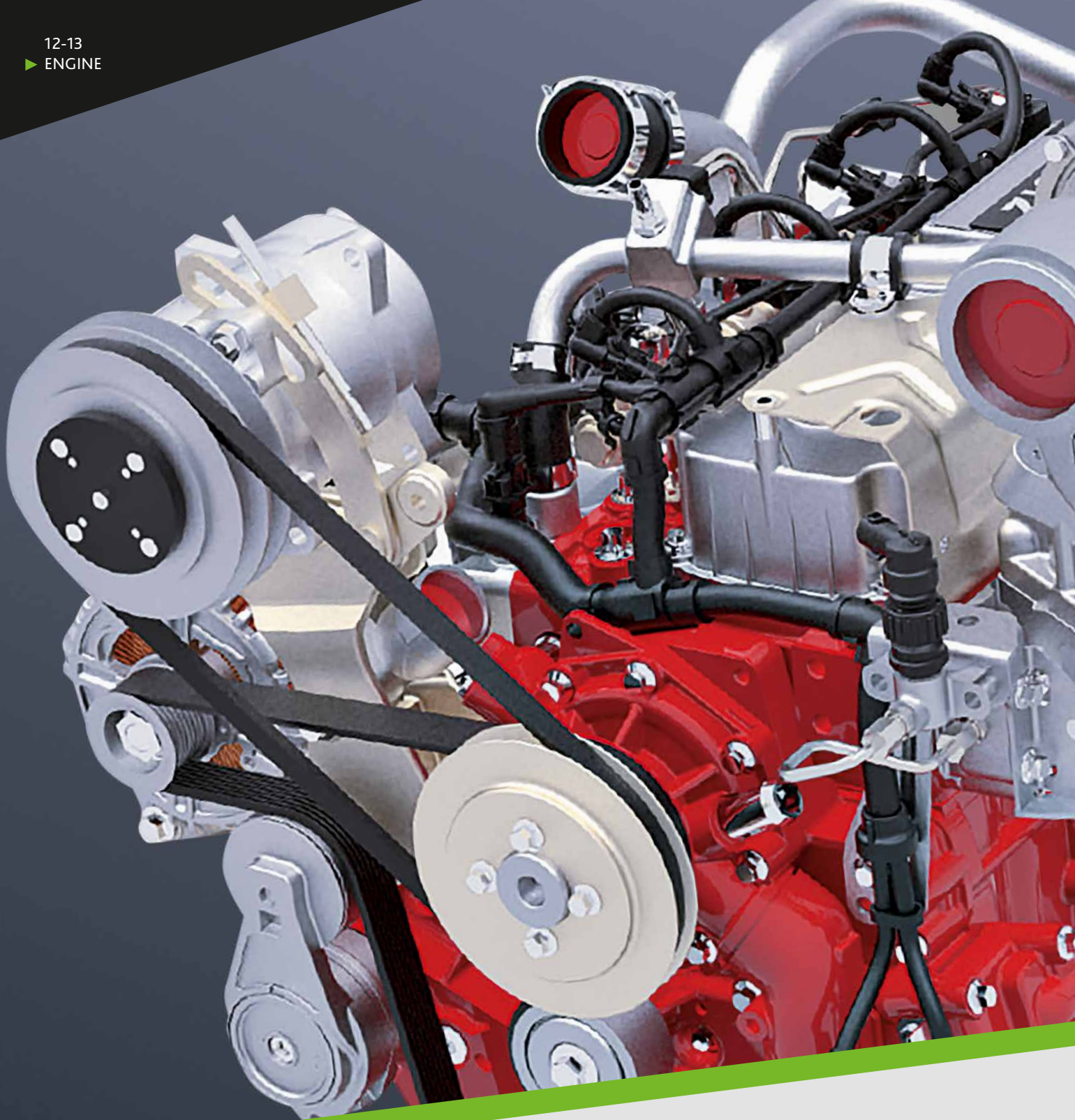

COMFORTABLE OUTPUT.  
COMFORTABLE FOR THE  
ENVIRONMENT.

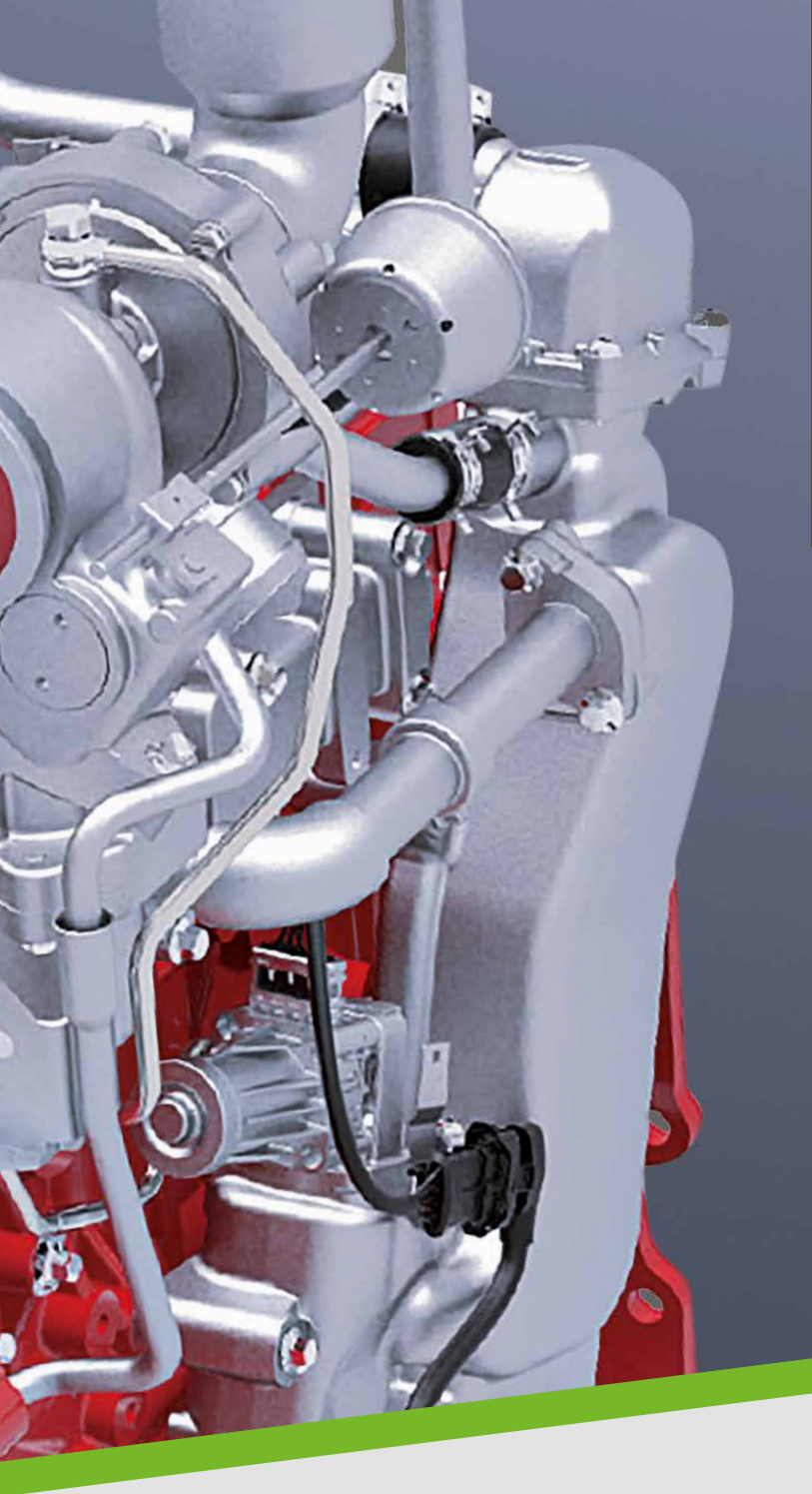

DEUTZ-FAHR 5125 Stage 4 (Tier 4F)

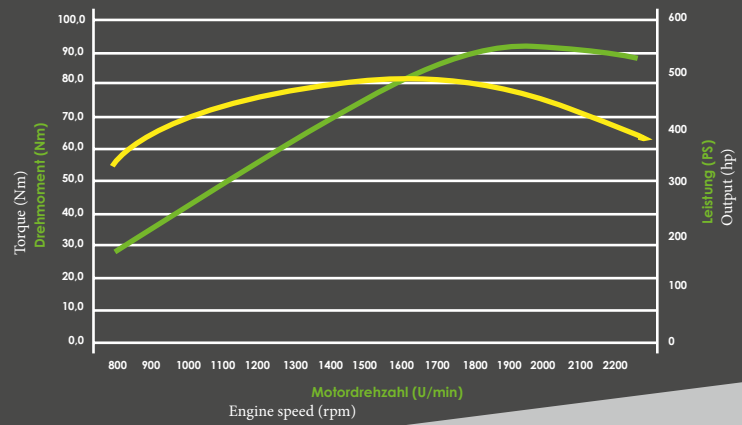

State-of-the-art exhaust gas purification technology such as SCR (Selective Catalytic Reduction) or...



... DOC (Diesel Oxidation Catalyst) catalyst ensure lowest emission values.



The Powercore air filter supports engine efficiency, as well as...



... the easy-to-clean cooling system with optional viscous fan.

High output, reliability and environment-friendliness – the compact Deutz 4-cylinder engines from 110 HP to 126 HP meet the requirements of Emission Class IV. The maximum torque is available at 1,600 rpm, with a torque reserve of 32%. Between 1,800 and 2,200 rpm, output remains constant. State-of-the-art engine technology, such as the DOC catalyst and the SCR system, ensure low emissions. Motor efficiency is enhanced by the Powercore air filter and cooling system with optional viscous fan. The cooling system can be accessed with a single step. Two removable safety nets make cleaning and maintenance easier.



# HOW EXACTLY DO YOU GET INTO GEAR?

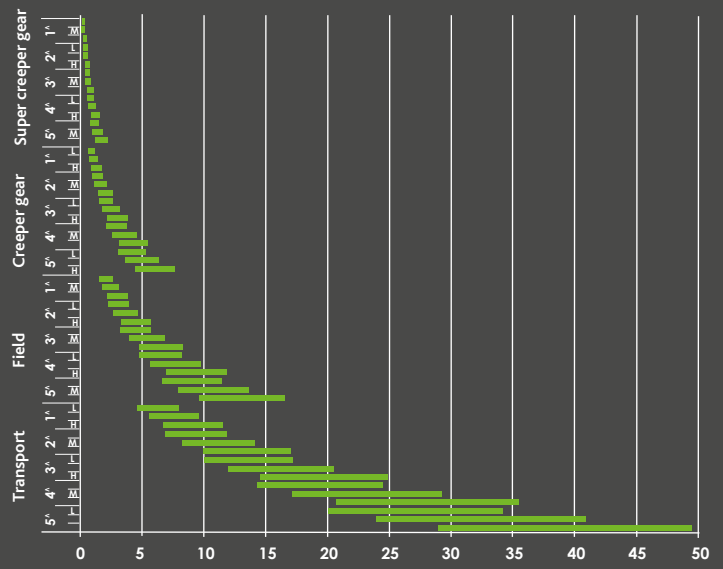

Comfort clutch and Powershift. Simply switch at the press of a button without engaging the clutch.



Powershuttle as a standard feature. Electrohydraulic powershuttle can only be set in 5 stages

When it comes to the transmission equipped, the 5 series demonstrates how comfortable a compact tractor can be. The highly efficient 5-speed transmission with electrohydraulic powershuttle, up to four gear shifting groups (slow, fast, creep or super creeper) with two or three powershift stages from 20 to 60 gears forward or reverse guarantees maximum efficiency in all variants. The top speed of 40 km/h at a reduced engine speed is not only economical – it is a matter of course. The increase or reduction of the speed under load is achieved using the powershift stages simply by pressing a button on the gear lever without engaging the clutch. The electrohydraulic powershuttle is equipped with two long-life multi-disc clutches in an oil bath. This makes it possible to change direction even under load at speeds up to 13 km/h. Powershuttle and the convenient Stop & Go function for stopping or starting without engaging the clutch are standard.

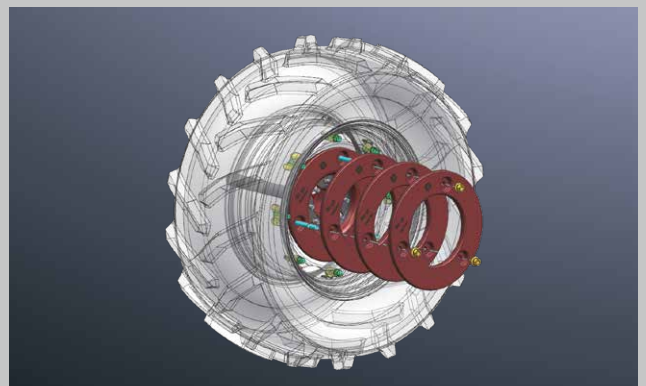

Rear-wheel ballasting. More stability, balance and traction from front-loader work to field use.

We know what counts on the farm, on the field and in the forest every day: output. To ensure your output, we place our top performance at your side: the compact tractors of the 5 SERIES.









**MAXIMUM DRIVING COMFORT  
AND SAFETY ON FIELD  
AND ROAD.**



Unique safety concept of DEUTZ-FAHR. Separate oil-cooled disc brakes on the front wheels.

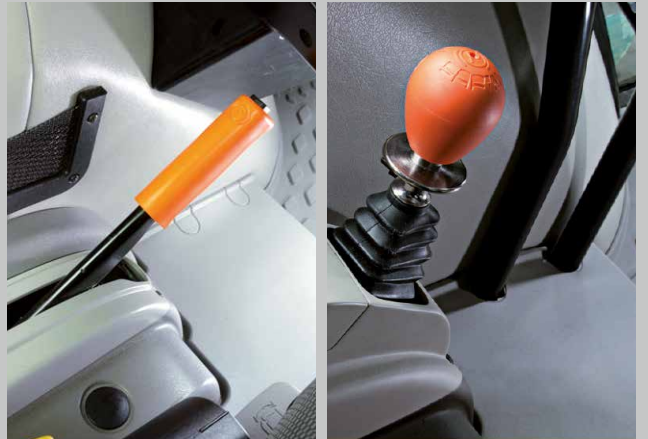

Mechanical or hydraulic parking brake. The choice is yours.



The SDD quick-steering system. Half steering wheel turn, double steering angle.

Driving comfort, manoeuvrability, safety and traction under all ground conditions are guaranteed by the 5 series front axle concept. The compact bonnet allows a steering angle of 55 degrees. The SDD quick steering system, which halves the steering wheel turns, is optionally available for all models. And safety has top priority at DEUTZ-FAHR. The front axle is – like the rear axle – equipped with disc brakes. In addition, the all-wheel drive is switched on. The optional front-axle

suspension provides additional driving comfort. The standard version includes the mechanical parking brake, while a hydraulic parking brake is optional. In this way, you can reliably secure the 5 series even on steep slopes. Electrohydraulic engagement of the differential lock and all-wheel drive is also standard. A 100% locking effect on front and rear axle is available for all models.



Performance and comfort are not contradictory. The proof? THE 5 SERIES. We can not relieve you of long working days, but we will make them as pleasant as possible for you.





HOW TO MOVE EVEN THE  
HEAVIEST DEVICE WITH  
MAXIMUM COMFORT.



Front attachment area. 2,100 kg lifting power and 1,000 version PTO.



The "High-Flow" hydraulic valves. More output where it's needed.



External PTO and linkage operation for easy device coupling and external PTO operation.

Attachment areas also demonstrate how comfortable you can work with a compact tractor. With the 5 series, you have almost all conceivable device combinations precisely under control. Three different hydraulic systems are available - 55l/min, 60l/min ECO and 90l/min. Double open-centre hydraulic pumps with up to 90l/min pump capacity and new "high-flow" hydraulic valves deliver impressive performance - but only where needed, of course. Up to four control units, three mechanical and one electrical, are controllable. For this purpose, a flow rate up to 80l/min and various operating conditions, such as floating position, continuous flow and a

kick-out function, are available. The rear linkage and control units can be operated independently of each other. When it comes to the PTO, the 5 series offers far more than average compact tractors. Up to four PTO speeds - 540/540 ECO/1000/1000 ECO - are available in the rear. The front PTO runs at 1,000 rpm. As standard, the electrohydraulic engagement with an automatic rear linkage position-dependent function is provided. The rear lifting capacity is an impressive 5,400 kg. The front linkage raises a whopping 2,100 kg. The electronically controlled rear linkage is standard.



Good weather does not last forever. When the harvest come, full dedication is needed from everyone. Day and night. Maximum working comfort brings maximum motivation. Change to THE 5 SERIES now.







LET'S START AT THE  
BEGINNING: COMFORTABLE  
FRONT LOADER WORK  
WITH THE 5 SERIES.



Front loader joystick with powershift buttons, Stop&Go and SDD quick steering system, and all...



... controls for front loader operation are fully integrated and easy to reach.

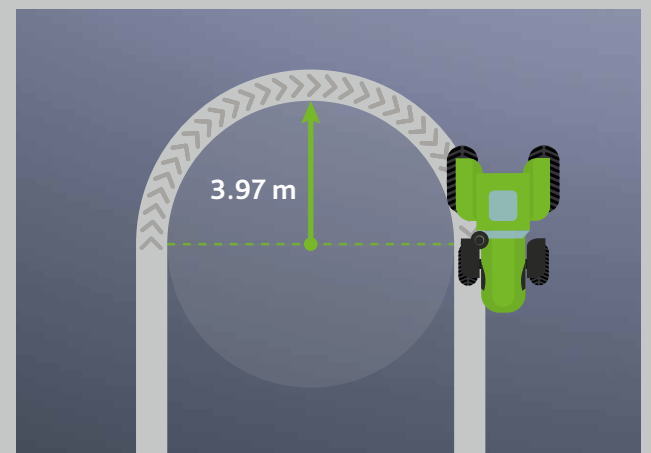

A turning radius of up to 3.97m (depending on tyres and optimum conditions) allows manoeuvring in the tightest of situations.

Feed, grain, soil, bales or even work platforms - there is something to lift, shovel, load or shift every day. A look at the compact models of the 5 series is enough to say, "These are ideal front-loader tractors." Powershuttle, Stop & Go, and the SDD quick-steering system make them manoeuvrable and agile. The additional disc brakes on the front wheels guarantee safety, the double hydraulic pumps with outputs up to 90 l/min provide lifting power, the rear wheel ballast brings stability and balance and the various roof window options offer the best view of the entire working area. The front loader is conveniently operated using a lever with a powershift function. How much front loader do you need? The Front Loader Light kit, in which the attachment points are preinstalled? Or the Front Loader Ready kit, where everything is preinstalled right up to the hydraulics? The choice is yours.

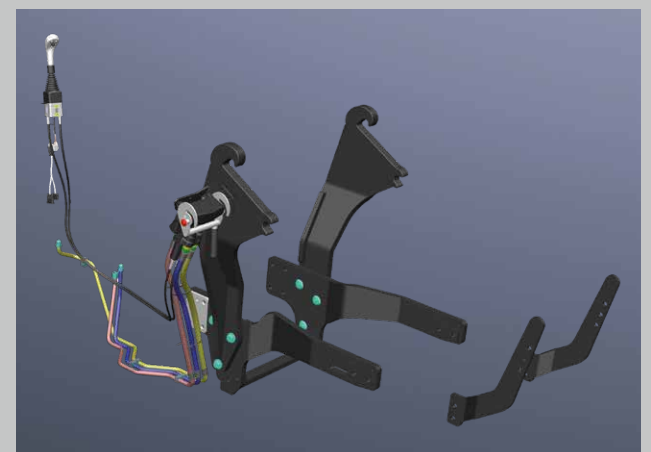

Front Loader Light or Front Loader Ready kit. The choice is yours.





Roads and area maintenance, cleaning work, transport tasks and winter service – in municipal use, THE 5 SERIES is far superior to other vehicle concepts thanks to its compactness and versatility. Day by day. All year long.

TECHNICAL DATA	SERIES 5			
	5105	5115	5125	
<b>ENGINE</b>				
Manufacturer		Deutz		
Model		TCD 3.6 L04		
Emissions stage		Emissions stage IV		
Cylinders/capacity	No./cm <sup>3</sup>	4/3,620	4/3,620	4/3,620
Turbo with intercooler		●		
Rigid fan		●		
Viscous fan		○		
Injection pressure	bar	1,600		
Maximum output (ECE R120) at 2,000 rpm	kW/HP	80.9/110	87.5/119	92.8/126
Output at rated speed (ECE R120) of 2,200 rpm	kW/HP	77/105	83/113	88/120
Max. torque	Nm (rpm)	440 (1,600)	476 (1,600)	500 (1,600)
Torque increase	%	32		31
Electronic engine control		●		
Exhaust gas treatment		SCR+DOC		
Power-Core air filter		●		
Exhaust tailpipe on the cab column		●		
Fuel tank capacity	Litres	135		
AdBlue tank volume	Litres	8		
<b>TRANSMISSION</b>				
Manufacturer		SDF		
Model		T5250	T5350	
Electrohydraulic powershuttle with 5 control stages (GS)		●		
Stop&Go system (GS)		●		
5-speed manual transmission with 2-speed powershift		●		
Number of gears	FW+RW	20+20		
Number of gears with creeper gear and super creeper gear	FW+RW	40+40		
5-speed manual transmission with 3-speed powershift		○		
Number of gears	FW+RW	30+30		
Number of gears with creeper gear and super creeper gear	FW+RW	60+60		
<b>PTO</b>				
Electrohydraulic engagement		●		
Rear PTO 540/540ECO	rpm	●		
Rear PTO 1000/1000ECO	rpm	○		
Ground speed PTO		○		
Front PTO 1000	rpm	○		
<b>AXLES AND BRAKES</b>				
Front axle suspension		○		
All-wheel drive with electrohydraulic engagement		●		
100% differential lock with electrohydraulic engagement		●		
4-wheel brake system		●		
Hydrostatic steering with independent pump		●		
SDD quick-steering system		○		
Steering angle	Degree	55		
Pneumatic trailer braking system		○		
Hydraulic trailer brake		○		
Mechanical parking brake		●		
Hydraulic parking brake		○		
<b>HYDRAULICS AND LINKAGE</b>				
Open-centre system hydraulic system		●		
Pump capacity (std.)	l/min	55		
Pump capacity (opt.)	l/min	60ECO		
Pump capacity (opt.)	l/min	90		
Hydraulic auxiliary control valves (rear)	Qty. (mech.+electr.)	2/3/3+1		
Rear linkage electronically controlled		●		
Rear linkage lifting capacity (cyl. 42mm)	kg	4,855	-	
Rear linkage lifting capacity (cyl. 50mm)	kg	-	5,410	

TECHNICAL DATA	SERIES 5			
	5105	5115	5125	
<b>HYDRAULICS AND LINKAGE</b>				
Front linkage		O		
Front linkage lifting capacity	kg	2,100		
<b>ELECTRICAL SYSTEM</b>				
Voltage	V	12		
Alternator	V/A	12/150		
Battery	V/AH/A	12/100/650		
<b>CAB</b>				
Hydro-Silent block bearing		●		
Air conditioning		O		
Open-view roof		O		
Driver's seat with mechanical suspension		●		
Driver's seat with pneumatic suspension		O		
Passenger seat		O		
<b>COUPLINGS</b>				
Automatic trailer hitch		●		
Spherical head coupling K80, height-adjustable		O		
Spherical head coupling K80, fixed		O		
Pickup hitch		O		
Drawbar		O		
<b>DIMENSIONS AND WEIGHTS</b>				
Standard tyres front	Tyre designation	380/85 R24	420/85 R24	340/85 R28
Standard tyres rear	Tyre designation	420/85 R34		420/85 R38
Max. front tyres	Tyre designation	440/65 R28		
Max. rear tyres	Tyre designation	540/65 R38		
Max. length	mm	4,145		
Wheelbase (4WD/2WD)	mm	2,370/2,330	2,370	2,370/2,330
Width (min./max.)	mm	2,170/2,400		
Height (min./max.)	mm	2,685/2,760		
Empty weight (basic/complete equipment)	kg	4,150/4,400	4,500/4,750	
Permissible total weight (4WD/2WD)	kg	7,500/5,300	7,500	7,500/5,300
Useful load (min./max.) (4WD)	kg	2,600/2,850	2,750/3,000	

●: Standard O: Optional -: not available

Sales partner

Marketing-Communication Service – Code 308.83511.5.4-6 – 07/19



For more information, please contact your DEUTZ-FAHR sales partner or visit [deutz-fahr.com](http://deutz-fahr.com).

DEUTZ-FAHR is a brand of  SDF

